

**SUBJECT:    Hosting the Riversimple Hydrogen fuel cell car trial**

**MEETING:   CABINET**

**DATE:        08 June 2016**

**DIVISION/WARDS AFFECTED: All**

**1. PURPOSE:**

- 1.1 To approve the hosting of a twelve month trial of 20 Riversimple Hydrogen cell cars in Monmouthshire

**2. RECOMMENDATION:**

- 2.1 That Monmouthshire County Council supports the trial of the Riversimple Rasa by the provision of space within a current open space or public car park to provide a refueling station and office/exhibition accommodation.
- 2.2 That the space be made available via license to Riversimple at no cost for a period of up to twelve months with an option to extend for a further twelve months (if required)
- 2.3 That the actual site (in either Abergavenny or Monmouth) and the details of the trial be approved by the Head Operations in consultation with the relevant Cabinet member following detailed discussions with Riversimple regarding safety of the vehicles and refuelling point.
- 2.4 That an invite be forwarded to all members to attend a presentation of the Riversimple Rasa car and concept. This to be held at 1.00 p.m. prior to Council on the 16<sup>th</sup> June 2016 (the car will be available at County Hall Usk for members to view).
- 2.5 That secure parking for up to 20 vehicles be provided at Raglan depot, if required, for the vehicles of motorists taking part in the trial.

**3. KEY ISSUES:**

- 3.1 The development of the Riversimple hydrogen car is an opportunity for Monmouthshire to be involved in the development of a completely new car concept. It is a unique opportunity and will draw a great deal of attention to the car but also to Monmouthshire as the host. (The Riversimple proposal is attached – appendix 1).

- 3.2 The trial will be open to residents and businesses from within Monmouthshire and surrounding areas.
- 3.3 The Riversimple concept of the provision of car transport is quite different to established conventions of car ownership and may herald the introduction of a new method of fuelling, acquiring and financing private transport.
- 3.4 The vehicle is powered by hydrogen so for the trial to operate a refuelling station must be created in the general vicinity of the trial. Riversimple consider a site in Abergavenny or Monmouth (car park or public open space) would provide an ideal location to place a refuelling station and office/exhibition unit. Discussions between officers of the council and Riversimple have so far focused on the provision of space in a car park or open space in Abergavenny or Monmouth (the North of the county is being favoured because the design of the Riversimple Rasa trial is biased towards a 'local' car rather than particularly aimed towards long distance motorway travel).
- 3.5 A typical layout for a Riversimple refuelling station and exhibition unit is provided in Appendix 2. Where approval of a site is on public open space/highway then there is no ongoing cost for Monmouthshire's involvement in the trial (outside of officer resource, advertising etc. to facilitate the trial and exploit the trial to the benefit of Monmouthshire). If the site is to be placed in an MCC public car park (typically the site would encompass say 6 parking spaces) then income will be lost when no alternative parking spaces are available.
- 3.6 A license would be prepared which would clearly state the companies responsibilities for insurances, maintain and compliance with statutory codes on an ongoing basis alongside the reinstatement and removal of structures at the end of the licence period.
- 3.7 Any structures that are erected will require a planning permission to be granted and will have highways considerations.
- 3.8 All civil works directly for connecting and reinstating the site following completion of the trial have been factored into the grant and will be funded by Riversimple.
- 3.9 Riversimple have secured European Funding for providing the 20 cars throughout the trial period and has approached Monmouthshire to be the host of the trial. They are able to host the project elsewhere but would like to work with Monmouthshire as Riversimple see it as a good showcase opportunity for the vehicle and demonstrates MCC's commitment to its sustainability and innovation priorities.

#### **4. REASONS:**

- 4.1 The vehicle is being developed in Wales and Riversimple would ideally wish to see the vehicle trial also being facilitated in Wales.
- 4.2 The option of hydrogen fuel cell cars are yet to become familiar to the general motoring public. A trial of such a car for a year will inevitably create interest amongst the public generally along with the motor industry. The trial being based in Monmouthshire will demonstrate Monmouthshire's commitment to new sustainable technology and Enterprise.
- 4.3 Involvement in such innovation in transport is completely in with the authority's priorities of a sustainability and compliments the principles of the Future Generations bill.

## **5. RESOURCE IMPLICATIONS:**

- 5.1 Loss of car parking income throughout the trial. Location and layout is yet to be determined and the impact on revenue will be minimised but will need to be balanced against practical considerations. The average income is £4 per space per day based on full occupancy on the assumption of 50% occupancy throughout the year this equates to or £730 per annum per space r £4,380 for the predicted 6 spaces.
- 5.2 Officer time to assist with the planning and implementation of the trial covering legal, promotional, practical and planning considerations.
- 5.3 Costs of infrastructure works (power supply, water supply etc.) will be paid by Riversimple ( this has been agreed since the production of the Riversimple document – appendix 1 which indicates that these costs are attributable to MCC).
- 5.4 Should it be required that secure parking for motorists taking part in the trial be provided at Raglan depot (up to 20 spaces).

## **6 RISKS:**

- 6.1 The company may fail during the trial period. This risk is mitigated through the use of a licence requiring reinstatement and the possession of goods prior to that event occurring, prior to the licence being granted MCC will require confirmation that an appropriate sum has been set aside for reinstatement.
- 6.2 The trial has problems and reputational damage occurs. An appropriate termination clause will be inserted into legal documentation allowing MCC to give notice and opt out should this occur. MCC will also require updates from the trial on a regular basis in the form of meetings or written reports in order to have early warnings of any issues of this nature.

## **5. CONSULTEES:**

All Cabinet Members  
Senior Leadership Team  
Head of Legal Services  
Head of Finance

## **6. BACKGROUND PAPERS:**

**Appendix 1 - Riversimple's Proposal for Partnership**  
**Appendix 2 – Typical Layout of a refuelling point**

## 7. AUTHORS AND CONTACT DETAILS

Roger Hoggins, Head of Operations  
[rogerhoggins@monmouthshire.gov.uk](mailto:rogerhoggins@monmouthshire.gov.uk)

Ben Winstanley  
[benwinstanley@monmouthshire.gov.uk](mailto:benwinstanley@monmouthshire.gov.uk)

# Appendix 1

## Riversimple's proposal for partnership with Monmouthshire County Council

### Executive Summary

This is a proposal to run a 12 month trial of 20 Riversimple hydrogen fuel cell cars in Monmouthshire, with a view to expanding commercially in the region after the trial. Designed and built in Powys, the Riversimple Rasa is possibly the most promising green car in the world:

"This Hydrogen-Powered Car Could Be The Future Of Sustainable Mobility"  
13/4/16

Huffington Post,



The Rasa runs on hydrogen. It resolves many of the challenges associated with battery electric cars; it has a range of 300 miles, refills in 5 minutes and there is no cost premium compared with a conventional car. It is the cleanest and most energy-efficient car yet offered for ordinary roadgoing use.

Riversimple is keen to run a trial of 20 Rasa cars with a variety of drivers in Monmouthshire, with a service hub in either Monmouth or Abergavenny.

The aims are threefold:

- 1) To test and refine the innovative service proposition. Riversimple is pioneering a different business model, offering mobility as a service instead of a car as a product. Customers will pay a monthly direct debit to cover all costs: maintenance, tyres, repairs, insurance and even fuel. Cardiff Metropolitan University has been engaged in the service design and is collaborating with Riversimple on all research angles.
- 2) To assess and refine the commercial case for investment in refuelling infrastructure. This is the first opportunity in the UK to see a cohort of hydrogen fuel cell cars used in a normal everyday way in a community. Building the business potential for the hydrogen refuelling station at the centre is a vital step in the commercialisation of the technology and infrastructure.
- 3) To act as a showcase for other Councils and authorities across the UK. The company plans to roll out across the UK one catchment at a time, in tandem with hydrogen refuelling stations placed in central locations convenient for the local community.

Riversimple has approached Monmouthshire County Council to partner in this trial in the following way:

- Endorsement of, and engagement with, the trial
- A site for central hydrogen refuelling point and small service centre
- Long term secure parking for max 20 cars
- Collaborating with Riversimple in identifying potential participants
- Sharing experience and insight with other Councils and authorities

Timing for the trial: starting end of 2016, to run for 12 months.

The trial is supported by an EU grant of €2m and the company is currently raising matching funds.

#### Potential benefits to Monmouthshire

In this very dispersed county, transport is critical to employment, wellbeing and a sense of community. Safe, efficient, clean cars can contribute positively.

There is potential economic and social benefit from the Riversimple service centre, as a hub for green activities.

It adds to the Council's regional reputation as a visionary Council, technologically and environmentally.

It puts Monmouthshire at the forefront of sustainable transport development in the UK and beyond, and opens up longer term opportunities for development of integrated low carbon energy and transport infrastructure based on hydrogen.

It helps to anchor Riversimple in Wales, and Wales as the pioneering region in the UK for hydrogen technology.

### Appeal of Monmouthshire to Riversimple

The diverse topography and regular short distances between the towns are ideal for testing the Rasa cars, which are designed for local, non-motorway use (max speed 60 mph).

It is close to Riversimple's R&D HQ in Llandrindod Wells, so easy to monitor and service. And close to the border, so easily visible for the rest of the UK.

MCC are Early Adopters of the Wellbeing of Future Generations Act - Riversimple is keen to learn from the Council's experience of delivering and auditing improvements to wellbeing in the community.

Shared values: open and transparent governance, protecting and balancing benefit streams for multiple stakeholders. Riversimple answers to 6 Custodians, representing Customers, Staff, Investors, Commercial Partners, the Environment, and the Community.

### Background about Riversimple

Riversimple Movement Ltd is headquartered in Llandrindod Wells and was awarded a £2m Research Development and Innovation grant from the Welsh Government in 2015 towards the prototype of its 2 seat hydrogen car.

The road legal engineering prototype of the Rasa, built to full EU type approval standards, was launched on 17<sup>th</sup> February to great acclaim. For vehicle specification and performance, please see appendix.

On top of the Welsh grant, the company has secured a €2m grant from the EU for a commercial trial of 20 cars, to begin by the end of 2016 and run for 12 months.

Following the trial, Riversimple intends to go into production late 2018. The company is currently in discussion with the Welsh Government about manufacturing locations, looking in the first instance in Powys. The company is pursuing a distributed manufacturing model of small-scale plants, with a capacity of 3,750-5,000 cars per annum, distributed around a central service hub. Each plant will employ c.220 people.

The Rasa is just the first vehicle that Riversimple intends to bring to market. It will be followed by light commercial vehicles and ultimately 5 seat intercity cars. Each vehicle will have its own plant.

### The details about the trial

3 – 6 month contracts will be offered to c. 60-80 users over a period of 12 months, and 20 Rasa cars will be hand built for their use.

We are aiming for a variety of users - younger and older, men and women, with and without children, urban and rural, personal, corporate and car-sharing.

Triallists will all be invited to place a data logger in their current cars to track their normal car use for 3 months prior to the trial to give us a usage benchmark.

They will be expected to go through the sign-up procedure and to pay the deposit and monthly fee. They will also be offered secure parking for their current cars for the duration of the trial.

Regular gatherings, shared feedback, dialogue with designers and engineers, and 24/7 technical support will form part of the trial. The onsite support team will comprise 3 people.

Driving data, including observed changes in driver behaviour, will be assessed, as well as satisfaction with the Riversimple experience, and perceptions of pricing and value.

Handovers after 3 months (or 6 months, in some cases) will be occasions for technical software updates, refining the sign-up process and trying out different pricing models; for example, including a fixed number of miles in a monthly tariff.

We will be tweaking and refining the offer until we are confident that we have the best possible brief for the production cars and the launch service.

### Refuelling site



Discussions have focused on placing a mobile hydrogen refuelling point in one of the Council car parks. The refuelling point would be self-service. The refuelling procedure is very similar to petrol or diesel, in that a hose is attached to the tank and the gas is transferred, although in this case under pressure, with a fill taking less than 5 minutes. Users would be identified by card or PIN number.

### Expected Costs

Riversimple will incur costs for the following:~

1. Supply of 20 cars
2. Staff to man refuelling site
3. All running costs for the car including fuel, insurance, repairs, service, tyres etc.
4. Temporary building for Riversimple experience centre
5. Management of customer relationship, billing and data collection

It would be helpful if Monmouthshire County Council could provide the following:~

1. Site in Monmouth for temporary building, re-fueller, car parking for 6 cars
2. Hard standing and service (Water, 3 phase electricity, mains, foul drain)
3. Officers' time to help build awareness and encourage citizen engagement
4. Help with planning application and any necessary planning requirement
5. Promotion of the trial, and customer feedback should MCC choose to be a trial Rasa customer

### Conclusion

The Monmouth and Riversimple partnership can bring a momentous change in the way mobility is delivered in a sustainable way. This trial is the first of its kind in the UK and will be of global interest to the world.

Appendices:

1. Refuelling site requirements
2. Vehicle specifications in EU trial ( SWARM)
3. Safety features of the Rasa

## Appendix 2

### : Refuelling site requirements and safety

Riversimple are seeking to implement a hydrogen refuelling point in the Monmouthshire area to support a beta trial of 20 hydrogen fuel cell vehicles. A request for proposal for hydrogen refuelling equipment is currently being negotiated with several suppliers and a final solution is yet to be selected. However, any solution will likely incorporate a stand-alone hydrogen refuelling point and compressed hydrogen storage. High level requirements include:

- Hard standing area;
- Sufficient access for trial vehicles, equipment delivery and installation and hydrogen delivery (unless hydrogen is produced on site using an electrolyser);
- Space for the dispenser, ancillaries and safety zoning, nominally 150m<sup>2</sup>;
- Sufficient utilities, electricity supply 3 x 400V including neutral and ground – 50 Hz, water supply (if an electrolyser is present);
- Scope for the implementation of protective structures if necessary, e.g. bollards for crash protection.

Once an equipment solution and site have been selected Riversimple would develop a detailed project plan and organise a kick-off meeting including all stakeholders to start the planning and installation of the refuelling station.

Figures 1 and 2 provide an indicative refueller and site plan. These are subject to change dependant on the final site and equipment selected.



Figure 1: McPhy refuelling station (connection to stored hydrogen not shown)

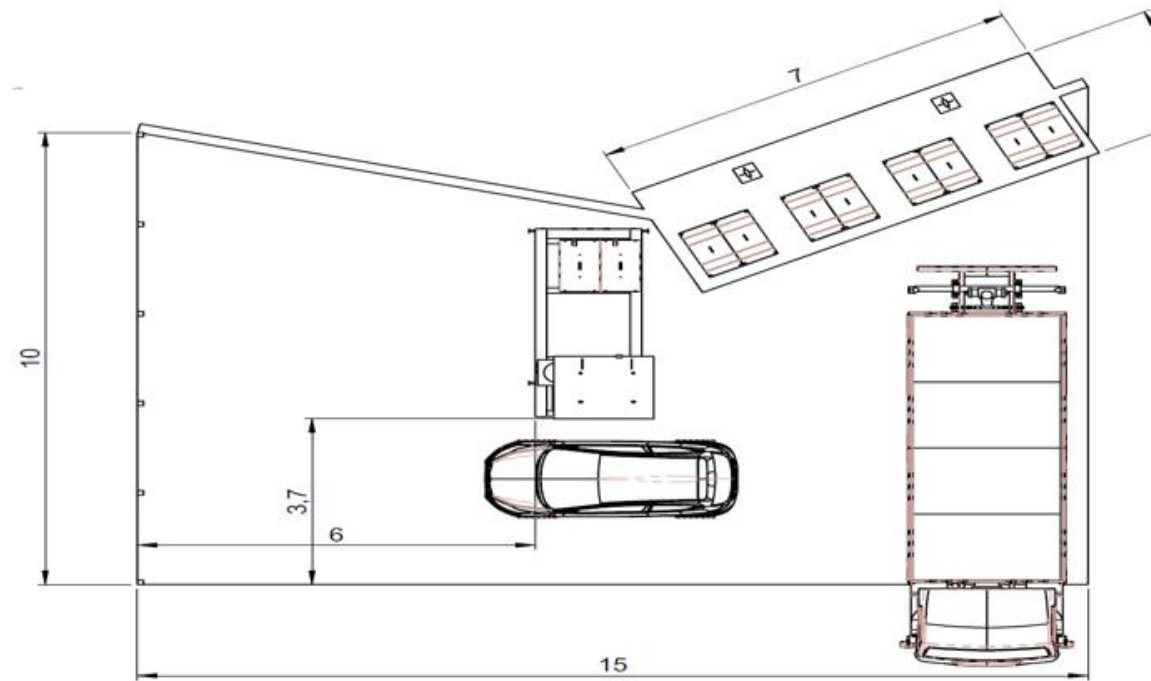

Figure 2: Indicative site plan for the McFilling station

### *Safety considerations*

Safety is the most important criteria in selecting and installing and hydrogen refuelling station. Safety features will include:

- Refuelling connection compliant with international standards (SAE J2601), including breakaway coupling, over pressure/temperature protection;
- Installation compliant with all applicable European directives: Machine, Low voltage, ATEX, Pressure Equipment;
- Systems for the detection of hydrogen leakage, fire and an emergency stop;
- Completion of a site safety case and implementation of necessary mitigations, including safety notices, security and crash protection.



<p><b>Name of the Officer</b> completing the evaluation Roger Hoggins/ Ben Winstanley</p> <p><b>Phone no:</b> 01633 644133 <b>E-mail:</b> rogerhoggins@monmouthshire.gov.uk Benwinstanley@monmouthshire.gov.uk</p>	<p><b>Please give a brief description of the aims of the proposal</b> To host the trial of a prototype hydrogen cell car developed by Riversimple. The trial will aid the development of the car to full production and supports the Council's commitment to sustainability and innovation</p>
<p><b>Name of Service:</b> Not applicable</p>	<p><b>Date Future Generations Evaluation</b> 27/05/2016</p>





1. **Does your proposal deliver any of the well-being goals below?** Please explain the impact (positive and negative) you expect, together with suggestions of how to mitigate negative impacts or better contribute to the goal.

<b>Well Being Goal</b>	<b>How does the proposal contribute to this goal? (positive and negative)</b>	<b>What actions have been/will be taken to mitigate any negative impacts or better contribute to positive impacts?</b>
<p><b>A prosperous Wales</b> Efficient use of resources, skilled, educated people, generates wealth, provides jobs</p>	<p>The car is being developed by a Welsh based company. This has already created work but a successful development to full production offers further oppoertunities for employment and skilled work assuming the company remains in Wales</p>	
<p><b>A resilient Wales</b> Maintain and enhance biodiversity and ecosystems that support resilience and can adapt to change (e.g. climate change)</p>	<p>The hydrogen cell car only emits water vapour so theer is no exhaust pollution from the car. The creation of hydrogen requires electricity but with the increasing commitment to renewables then transport by electricity or hydrogen powerd cars is a positive step towards reduction in fossil fuel energy consumption.</p>	

Well Being Goal	How does the proposal contribute to this goal? (positive and negative)	What actions have been/will be taken to mitigate any negative impacts or better contribute to positive impacts?
<b>A healthier Wales</b> People's physical and mental wellbeing is maximized and health impacts are understood		
<b>A Wales of cohesive communities</b> Communities are attractive, viable, safe and well connected		
<b>A globally responsible Wales</b> Taking account of impact on global wellbeing when considering local social, economic and environmental wellbeing	The development of vehicles powered by hydrogen is just starting to gain some momentum. Toyota , Hyundai and Renault have limited models available but the Riversimple Rasa is a completely new design and quite different in its concept of how transport will be provided in the future. If the concept is successful then it will have been created in Wales.	
<b>A Wales of vibrant culture and thriving Welsh language</b> Culture, heritage and Welsh language are promoted and protected. People are encouraged to do sport, art and recreation		
<b>A more equal Wales</b> People can fulfil their potential no matter what their background or circumstances		

**2. How has your proposal embedded and prioritised the sustainable governance principles in its development?**

Sustainable Development Principle	How does your proposal demonstrate you have met this principle?	What has been done to better to meet this principle?
-----------------------------------	---	--

Sustainable Development Principle	How does your proposal demonstrate you have met this principle?	What has been done to better to meet this principle?
 <p>Long-term Balancing short term need with long term and planning for the future</p>	<p>The hydrogen car offers a much more sustainable method of transport for the future and helps to reduce pollution by fossil fuels and electricity production becomes increasingly sustainable.</p>	
 <p>Collaboration Working together with other partners to deliver objectives</p>	<p>Riversimple has been working with organisations in wales on the development of the car. It is also receiving EU grant to support the trial. This is an opportunity for Monmouthshire to also contribute to the project.</p>	
 <p>Involvement Involving those with an interest and seeking their views</p>		
 <p>Prevention Putting resources into preventing problems occurring or getting worse</p>		
 <p>Integration Positively impacting on people, economy and environment and trying to benefit all three</p>	<p>This is a trial and is a key part to developing the car to a commercial production stage. As such there is a risk that the car will not develop further. On the assumption that it does become a viable project then it offers benefits to the environment through reduced emmissions, the economy through manufacture and people through employment or an alternative transport option.</p>	

**3. Are your proposals going to affect any people or groups of people with protected characteristics?** Please explain the impact, the evidence you have used and any action you are taking below.

<b>Protected Characteristics</b>	<b>Describe any positive impacts your proposal has on the protected characteristic</b>	<b>Describe any negative impacts your proposal has on the protected characteristic</b>	<b>What has been/will be done to mitigate any negative impacts or better contribute to positive impacts?</b>
Age	N/A		
Disability	N/A		
Gender reassignment	N/A		
Marriage or civil partnership	N/A		
Race	N/A		
Religion or Belief	N/A		
Sex	N/A		
Sexual Orientation	N/A		
Welsh Language	N/A		

4. Council has agreed the need to consider the impact its decisions has on important responsibilities of Corporate Parenting and safeguarding. Are your proposals going to affect either of these responsibilities? For more information please see the guidance <http://hub/corporatedocs/Democratic%20Services/Safeguarding%20Guidance.docx> and for more on Monmouthshire's Corporate Parenting Strategy see <http://hub/corporatedocs/SitePages/Corporate%20Parenting%20Strategy.aspx>

	<b>Describe any positive impacts your proposal has on safeguarding and corporate parenting</b>	<b>Describe any negative impacts your proposal has on safeguarding and corporate parenting</b>	<b>What will you do/ have you done to mitigate any negative impacts or better contribute to positive impacts?</b>
Safeguarding	No safeguarding or parenting implications are anticipated as a result of these proposals		
Corporate Parenting			

5. What evidence and data has informed the development of your proposal?

This is an opportunity for MCC to contribute to the production of a hydrogen cell car that is being developed in Wales. The trial is managed wholly by Riversimple with grant support from the EU so there is no financial risk to MCC so overall it compliments MCC's sustainability and innovation priorities and suggests that the proposal is a sensible commitment.



**6. SUMMARY:** As a result of completing this form, what are the main positive and negative impacts of your proposal, how have they informed/changed the development of the proposal so far and what will you be doing in future?

--

**7. Actions.** As a result of completing this form are there any further actions you will be undertaking? Please detail them below, if applicable.

<b>What are you going to do</b>	<b>When are you going to do it?</b>	<b>Who is responsible</b>	<b>Progress</b>

**8. Monitoring:** The impacts of this proposal will need to be monitored and reviewed. Please specify the date at which you will evaluate the impact, and where you will report the results of the review.

<b>The impacts of this proposal will be evaluated on:</b>	<b>We will agree a programme of updates with Riversimple during the period of the trial.</b>
---	--